

# LEGNOBAGNO

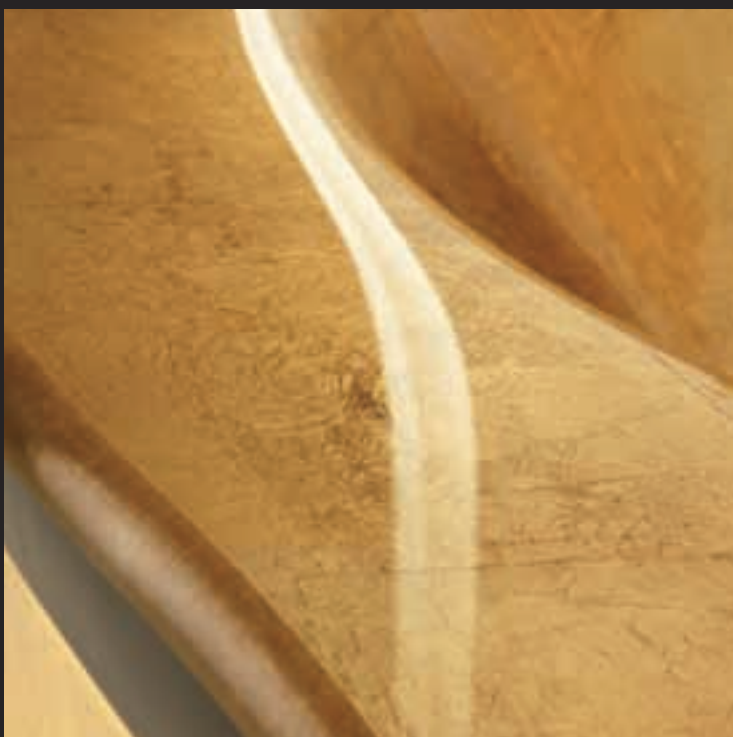

MONOBLOCCHI

STYLE  
COLLECTION



# STYLE COLLECTION



Innamorarsi a colpo d'occhio di un qualunque mobile di questa collezione, significa aver scelto un prodotto di grande pregio. Sono realizzati interamente in legno massello di provenienza europea e in legno multistrato specie in alcune parti curvate. Sono prodotti assolutamente artigianali e personalizzati, il lavoro manuale nella realizzazione di questi mobili gioca un ruolo fondamentale.

Non è superfluo dire che tutti questi prodotti sono fabbricati interamente in Italia: dal lavoro di falegnameria alla laccatura alla scelta di ogni singolo materiale. Ogni mobile è un pezzo unico che esce al di fuori della concezione di produzione industriale in serie: pochi pezzi, prodotti con grande cura e attenzione al particolare. Nella realizzazione di questi mobili non ci si è risparmiati nella scelta di ogni materiale e nella onerosità di finiture e lavorazioni... Tecnicamente tutti i mobili sono equipaggiati di moderne guide con chiusura assistita e si possono ottenere in molteplici finiture: laccato lucido e opaco, anticato, noce antico, spigolato o rivestito in foglia.

*Falling in love at first sight with any of the pieces in this furniture collection means choosing a product of great value. Our furniture is made entirely of solid European wood and of bent plywood, especially for some curved elements. These products are completely hand-crafted and custom made. The manual element in the construction of this furniture plays a vital role.*

*It goes without saying that all of these products are manufactured entirely in Italy, from the carpentry work to the finish color and even in the choice of every type of material used. Each piece of furniture is a unique piece that goes beyond the concept of industrial mass production: few pieces, all made with great care and attention to detail. In the construction of this furniture we have not stinted in the choice of our materials and finishes or in the seriousness with which workmanship and finishes are applied. In terms of technical specifications, all of the furniture is equipped with modern guides and assisted closures, and the pieces can be obtained in many different finishes: gloss, matte, antique, antique walnut, rubbed-through or gold/silver leaf.*

**LEGNOBAGNO®**

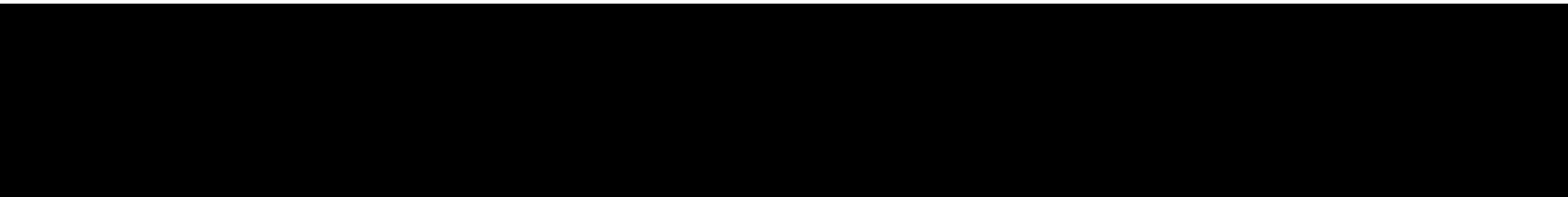

STYLE COLLECTION



VANITY	5
NARCISO	39
VOGUE	61
NOVECENTO	87

# VANITY



Classico ed intramontabile... linee morbide e sinuose evocano la sua tradizione artigiana. La sua fondamentale caratteristica sta nelle complesse curvature della parte frontale e dei fianchi. Derivato da un classico comò in stile veneziano, il Vanity è attualizzato e opportunamente stilizzato per essere in vario modo ambientato a contesti eterogenei: prettamente classico, elegante o più giovane e moderno. Il Vanity è disponibile in due versioni: classico monoblocco con due cassettoni, o elegante e minimale consolle con un solo cassetto.

*Classic and timeless...soft and sinuous lines evoke its craftsman tradition. Its key feature is the complex curvature of the front and sides. Derived from a classic Venetian-style commode, the vanity has been updated and appropriately styled to fit beautifully into various environments and a broad range of settings: purely classical, elegant, or younger and contemporary. The Vanity is available in two different versions: the classic one-piece with two drawers, or an elegant and minimalist cabinet with a single drawer.*





# VANITY 01



**Colore Composizione:**

Laccato bianco lucido.

**Materiali:**

Realizzato quasi interamente in legno massello, alcune parti interne e i frontali curvati sono in legno multistrato.

**Specchiera e illuminazione:**

Legno massello, lampade a muro in ottone cromato con paralume in stoffa bianca.

**Top:**

Cristallo integrato "float spessore 15 mm", nero.

**Color Composition:**

Gloss white lacquer.

**Materials:**

Made almost entirely of solid wood, several internal parts and curved fronts are made of plywood.

**Mirror and Lighting:**

Solid wood, chromed brass wall lights with white fabric shades.

**Top:**

Integrated black float glass top, 15 mm thick.

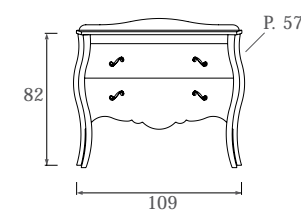
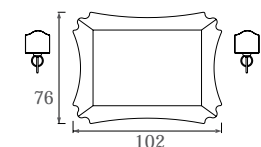





**Colore Composizione:**

Laccato nero lucido.

**Materiali:**

Realizzato quasi interamente in legno massello, alcune parti interne e i frontali curvati sono in legno multistrato.

**Specchiera e illuminazione:**

Legno massello, lampade a muro in ottone cromato con paralume in stoffa bianco.

**Top:**

Marmo Starlight White con lavabo sottopiano.

**Color Composition:**

Black gloss lacquer.

**Materials:**

Made almost entirely of solid wood, several internal parts and curved fronts are made of plywood.

**Mirror and Lighting:**

Solid wood, chromed brass wall lights with white fabric shades.

**Top:**

Starlight white marble with under-mount basin.

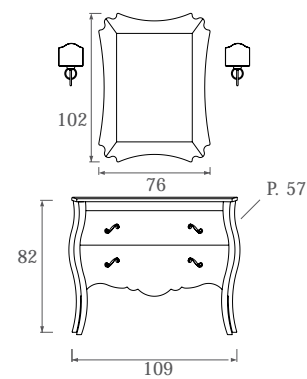







**Colore Composizione:**

Noce antico.

**Materiali:**

Realizzato quasi interamente in legno massello, alcune parti interne e i frontali curvati sono in legno multistrato.

**Specchiera e illuminazione:**

Legno massello, lampade in ottone cromato.

**Top:**

Marmo Botticino ricomposto con lavabo sottopiano.

**Color Composition:**

*Antique walnut.*

**Materials:**

*Made almost entirely of solid wood, several internal parts and curved fronts are made of plywood.*

**Mirror and Lighting:**

*Solid wood, lights of chromed brass.*

**Top:**

*Botticino technical recomposed marble and under-mount basin.*

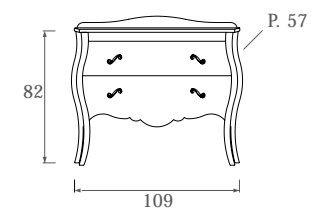
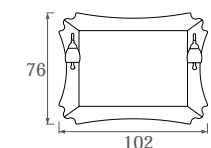





**Colore Composizione:**

Foglia argento.

**Materiali:**

Realizzato quasi interamente in legno massello, alcune parti interne e i frontali curvati sono in legno multistrato.

**Specchiera e illuminazione:**

Specchiera interamente in vetro con molatura rivestita in foglia argento, lampade a muro in ottone cromato.

**Top:**

Cristallo integrato "float spessore 15 mm", nero.

**Color Composition:**

Silver leaf.

**Materials:**

Made almost entirely of solid wood, several internal parts and curved fronts are made of plywood.

**Mirror and Lighting:**

Mirror entirely of glass with silver leaf adorned ground edge, chromed brass wall lights.

**Top:**

Integrated black float glass top, 15 mm thick.

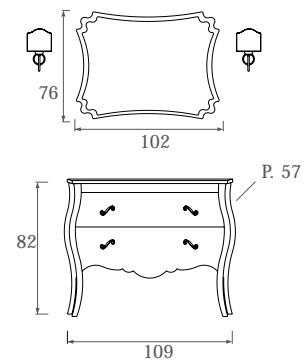



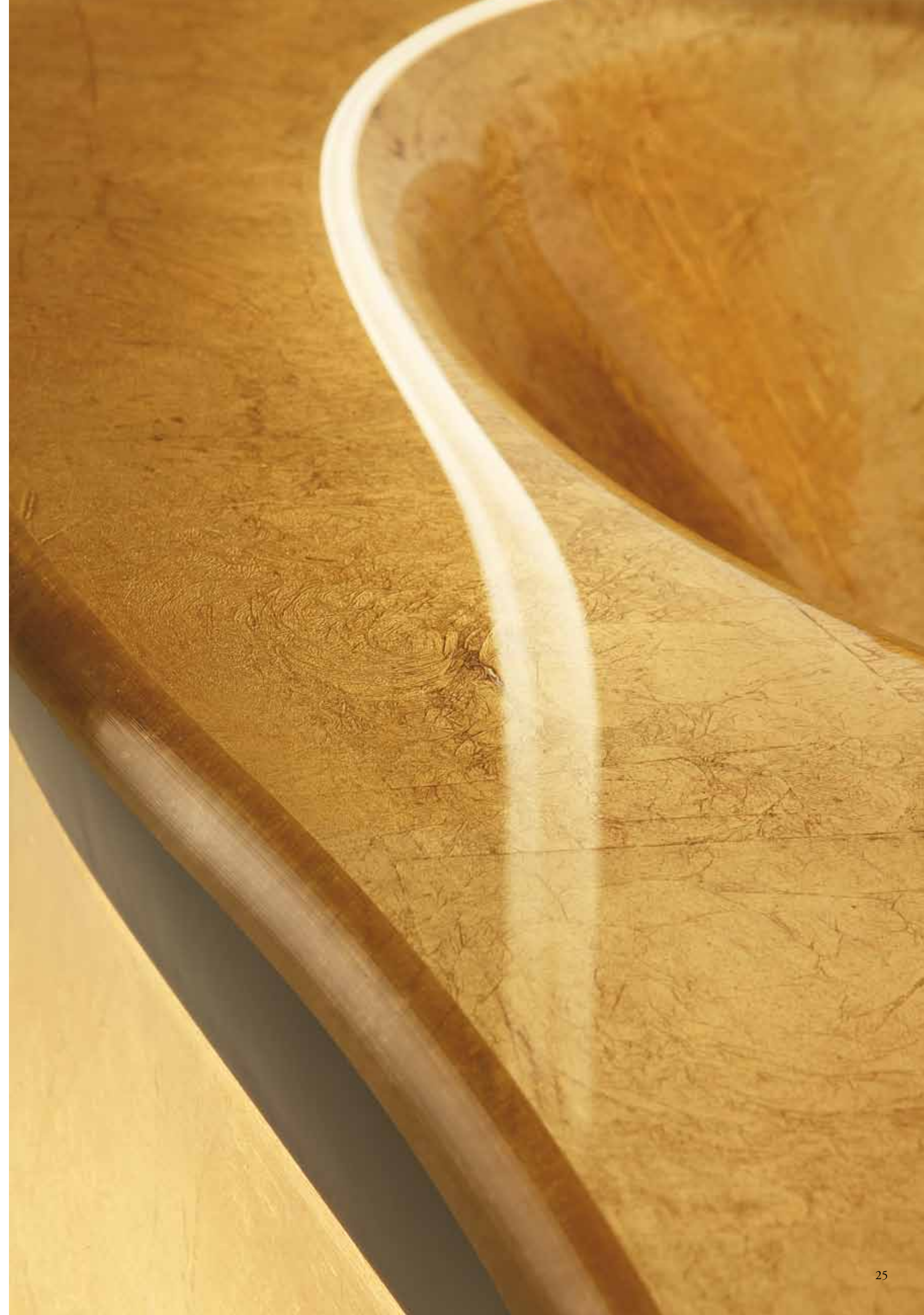

**Colore composizione:**  
Struttura nero lucido, cassettoni in foglia oro.

**Materiali:**  
Realizzato quasi interamente in legno massello, alcune parti interne e frontali curvati sono in legno multistrato.

**Specchiera e illuminazione:**  
Cornice specchiera in materiale poliuretano rivestita in foglia oro e specchio bisellato, lampade a muro in ottone dorato.

**Top:**  
Cristallo integrato "extrachiario spessore 15 mm". Rivestito in foglia oro.

**Color Composition:**  
Gloss black structure, drawers with gold leaf finish.

**Materials:**  
Made almost entirely of solid wood, several internal parts and curved fronts are made of plywood.

**Mirror and Lighting:**  
Mirror frame of polyurethane material finished in gold leaf and beveled mirror, gilded brass wall lights.

**Top:**  
Integrated extra-bright glass top, 15 mm thick, gold leaf finish.

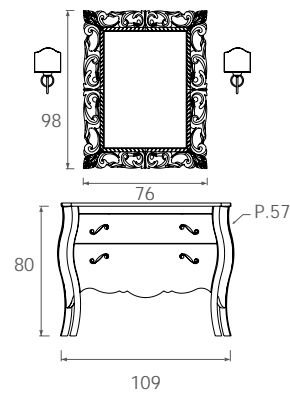





**Colore composizione:**  
Laccato bianco lucido.

**Materiali:**  
Realizzato quasi interamente in legno massello, alcune parti interne e frontali curvati sono in legno multistrato.

**Specchiera e illuminazione:**  
Cornice specchiera in materiale poliuretano laccata lucida e specchio bisellato, lampade a muro in ottone dorato.

**Top:**  
Cristallo integrato "extrachiaro spessore 15 mm", rivestito in foglia oro.

**Mobili di complemento:**  
Sgabello contenitore, realizzato in legno massello e multistrato.

**Color Composition:**  
White gloss lacquer.

**Materials:**  
Made almost entirely of solid wood, several internal parts and curved fronts are made of plywood.

**Mirror and Lighting:**  
Mirror frame of polyurethane material with high gloss finish and beveled mirror, gilded brass wall lights.

**Top:**  
Integrated extra-bright glass top, 15 mm thick, gold leaf finish.

**Complementary furniture:**  
Container stool, made of solid wood and plywood.

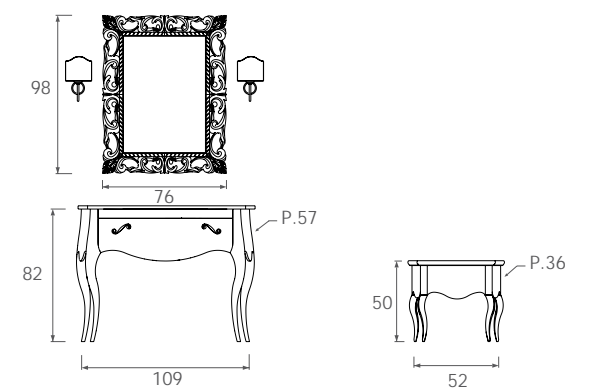







**Colore composizione:**

Laccato rosso porpora lucido.

**Materiali:**

Realizzato quasi interamente in legno massello, alcune parti interne e frontali curvati sono in legno multistrato.

**Specchiera e illuminazione:**

Particolare cornice a specchio curvata in fusione, lampade a muro in vetro e ottone cromato.

**Top:**

Cristallo integrato "extrachiaro spessore 15 mm", bianco.

**Color Composition:**

Deep-red gloss lacquer.

**Materials:**

Made almost entirely of solid wood, several internal parts and curved fronts are made of plywood.

**Mirror and Lighting:**

Unusual mirror frame curved in the process of fusion, wall lights of glass and chromed brass.

**Top:**

Integrated white extra-bright glass top, 15 mm thick.

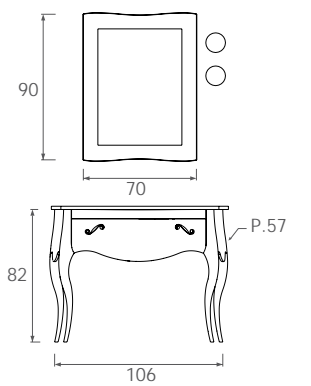





**Colore composizione:**

Noce antico.

**Materiali:**

Realizzato quasi interamente in legno massello, alcune parti interne e frontali curvati sono in legno multistrato.

**Specchiera e illuminazione:**

Legno massello, lampade a muro in ottone cromato.

**Top:**

Marmo tecnico botticino ricomposto e lavabo sottopiano.

**Mobile di complemento:**

Settimino realizzato in legno massello e multistrato.

**Color Composition:**

Antique walnut.

**Materials:**

Made almost entirely of solid wood, several internal parts and curved fronts are made of plywood.

**Mirror and Lighting:**

Solid wood, chromed brass wall lights.

**Top:**

Botticino technical recomposed marble and under-mount basin.

**Complementary furniture:**

Small chest of drawers made of solid wood and plywood.

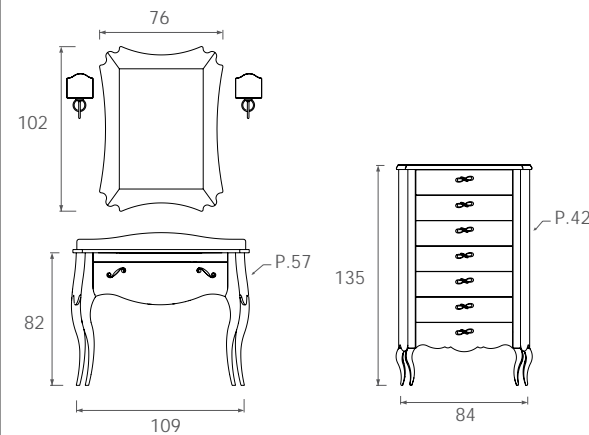

# NARCISO

Un classico, semplificato ed attualizzato, del mobile in stile veneziano. Disponibile in due versioni: con due ante o in alternativa due ante e due cassetti. A seconda degli abbinamenti di top e finiture, può adattarsi a contesti estremamente classici ed eleganti, come essere più moderno ed attuale.

*A classic, simplified and updated, of furniture in Venetian style. Available in two versions: either with two doors, or with two doors and two drawers. It adapts to extremely classical and elegant settings or to modern and contemporary settings depending on the combination of top and finish chosen.*

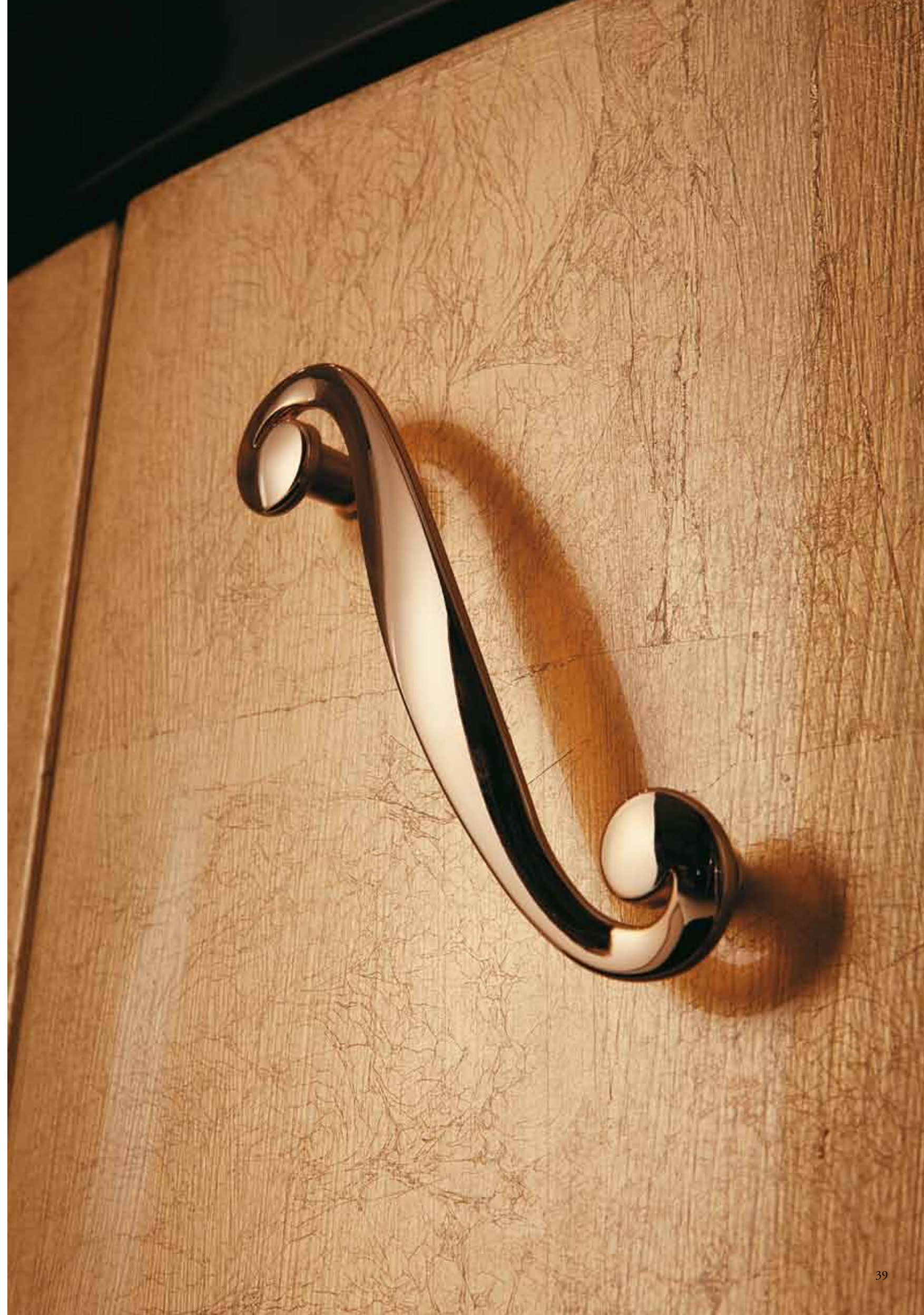





**Colore composizione:**

Laccato bianco lucido.

**Materiali:**

Struttura in legno massello, ante in legno multistrato.

**Specchiera e illuminazione:**

Cornice specchiera in materiale poliuretano laccato lucido e specchio bisellato, lampade a muro in ottone cromato.

**Top:**

Cristallo integrato "float spessore 15 mm". Nero.

**Mobile di complemento:**

"Comoncino" due ante e un cassetto, pensile con ante a vetrina realizzati in legno massello e multistrato.

**Color Composition:**

White gloss lacquer.

**Materials:**

Structure in solid wood, door of plywood.

**Mirror and Lightin:**

Mirror frame of polyurethane material with high gloss finish and beveled mirror, chromed brass wall lights.

**Top:**

Integrated black float glass top, 15 mm thick.

**Complementary furniture:**

Small commode with two doors and a drawer, hanging cabinet with glazed doors made of solid wood and plywood.

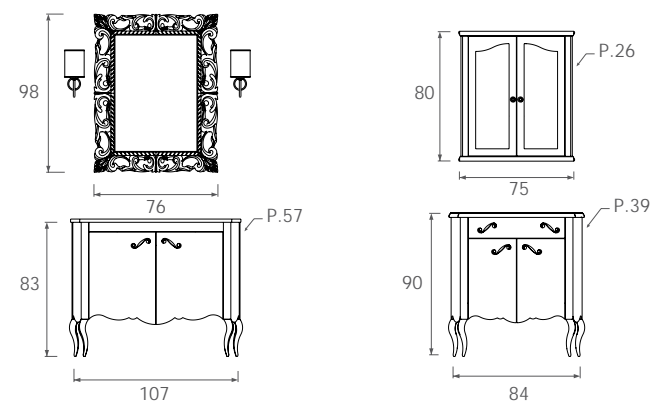







**Colore composizione:**  
Laccato rosso porpora lucido.

**Materiali:**  
Struttura in legno massello, ante in legno multistrato.

**Specchiera e illuminazione:**  
Specchiera in vetro fuso con scaglie di vetro, lampade a muro in ottone cromato.

**Top:**  
Marmo tecnico iceberg e lavabo sottopiano.

**Color Composition:**  
Deep-red gloss lacquer.

**Materials:**  
Structure in solid wood, doors of plywood.

**Mirror and Lightin:**  
Mirror in fused glass with glass flakes, chromed brass wall lights.

**Top:**  
Iceberg technical marble and under-mount basin.

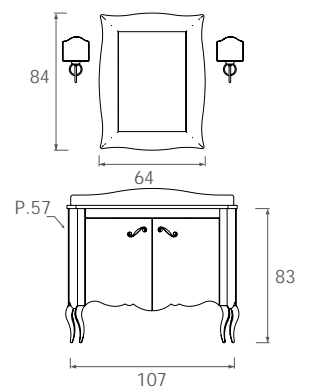



**Colore composizione:**

Struttura nero lucido, ante in foglia oro.

**Materiali:**

Struttura in legno massello, cassetti in legno multistrato rivestito con foglia oro.

**Specchiera e illuminazione:**

Specchiera interamente in vetro con molatura rivestita in foglia oro, lampade a muro in ottone dorato.

**Top:**

Cristallo integrato "extrachiaro spessore 15 mm", rivestito in foglia oro.

**Mobile complemento:**

Sgabello contenitore, realizzato in legno massello e multistrato.

**Color Composition:**

Structure black gloss, doors finished with gold leaf.

**Materials:**

Structure in solid wood, drawers of plywood with gold leaf finish.

**Mirror and Lightin:**

Mirror entirely of glass with silver leaf adorned ground edge, gilt brass wall lights.

**Top:**

Integrated extra-bright glass top, 15 mm thick, gold leaf finish.

**Complementary furniture:**

Container stool, made of solid wood and plywood.

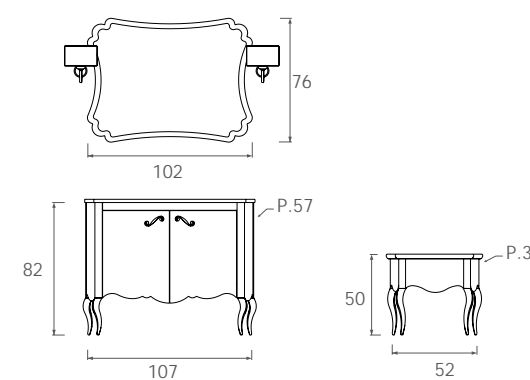





**Colore composizione:**

Laccato crema lucido.

**Materiali:**

Struttura in legno massello, Ante e cassetti in legno multistrato.

**Specchiera e illuminazione:**

Specchiera in legno massello, lampade a muro in ottone cromato.

**Top:**

Marmo tecnico botticino ricomposto e lavabo sottopiano.

**Mobile di complemento:**

Colonna alta con anta a vetrina e due cassetti, realizzata in legno massello e multistrato.

**Color Composition:**

Cream gloss lacquer.

**Materials:**

Structure in solid wood, doors and drawers of plywood.

**Mirror and Lightin:**

Mirror in solid wood, chromed brass wall lights.

**Top:**

Boiticino technical recomposed marble and under-mount basin.

**Complementary furniture:**

Tall column with glazed door and two drawers, made of solid wood and plywood.

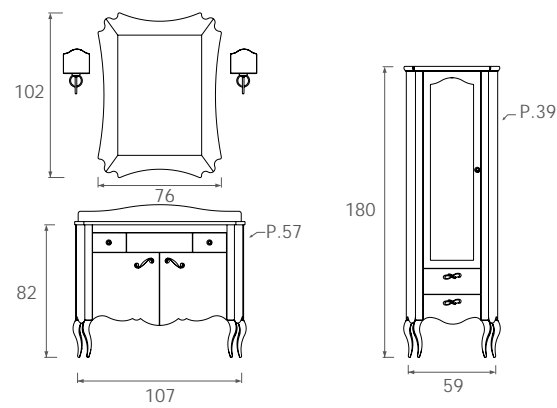





**Colore composizione:**

Noce antico.

**Materiali:**

Struttura in legno massello, ante e cassetti in legno multistrato.

**Specchiera e illuminazione:**

Legno massello, lampade in ottone cromato.

**Top:**

Marmo tecnico botticino ricomposto e lavabo sottopiano.

**Mobile di complemento:**

"Comoncino" due ante e un cassetto, pensile con ante a vetrina realizzati in legno massello e multistrato.

**Color Composition:**

*Antique walnut.*

**Materials:**

*Structure in solid wood, doors and drawers of plywood.*

**Mirror and Lightin:**

*Solid wood, lights of chromed brass.*

**Top:**

*Botticino technical recomposed marble and under-mount basin.*

**Complementary furniture:**

*Small commode with two doors and a drawer, hanging cabinet with glazed doors made of solid wood and plywood.*

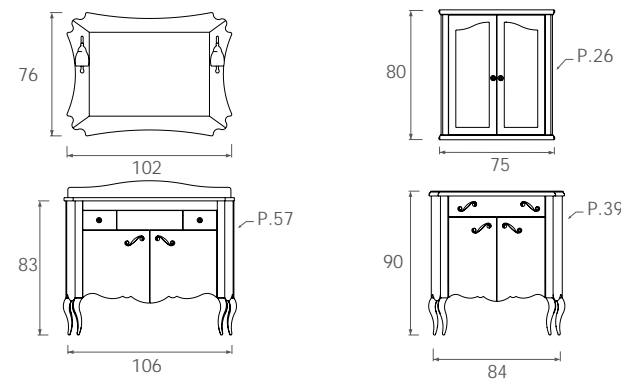

## VOGUE

Derivato da una consolle classica come caratteristico mobile da interno, il Vogue è forse fra tutti, il mobile più caratteristico e di particolare pregio. È disponibile in due versioni e misure: il più grande da 113 cm con quattro cassetti e il più piccolo da 104 cm con due cassetti. Il maggiore, di carattere più classico e di spettacolare eleganza, ben si presta alle finiture spigolate e al rivestimento in foglia. Il più piccolo, di carattere più moderno e "giovanile", risulta di particolare impatto nelle finiture laccate, oltre ad avere la possibilità di adattarsi al lavabo integrale in ceramica.

*Based on a classical console as a characteristic item of furniture, the Vogue is perhaps, among all of our furniture pieces, the most representative and of special desirability. It is available in two versions and sizes: the larger is 113 cm with four drawers and the smaller is 104 cm with two drawers. The larger is more classical and of spectacular elegance spectacular, and is well-suited to rubbed through finishes as well as to a gold leaf finish. The smaller version has a younger and more modern feel and it is an impressive in a lacquer finish. It is also able to accommodate either an integrated or under-mounted basin.*









**Colore composizione:**

Spigolato nero.

**Materiali:**

Realizzato quasi interamente in legno massello, alcune parti interne sono in legno multistrato.

**Specchiera e illuminazione:**

Legno massello, lampade a muro in ottone dorato.

**Top:**

Marmo giallo sahara e lavabo sottopiano.

**Mobile di complemento:**

Colonna bassa con anta e 3 cassetti, realizzata in legno massello e multistrato.

**Color Composition:**

Black rubbed-through finish.

**Materials:**

Made almost entirely of solid wood, several internal components of plywood.

**Mirror and Lighting:**

Solid wood, gilded brass wall lights.

**Top:**

Yellow Sahara marble and under-mount basin.

**Complementary furniture:**

Low column with door and three drawers, made of solid wood and plywood.

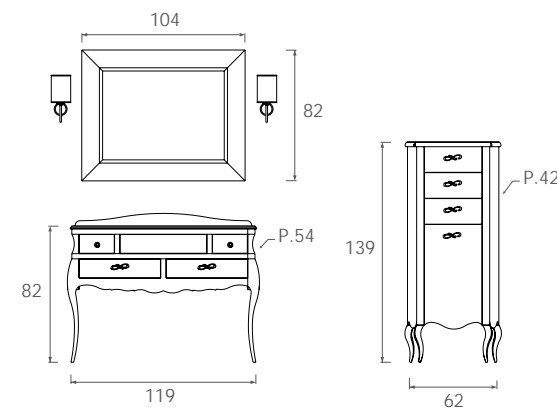





**Colore composizione:**

Spigolato rosso.

**Materiali:**

Realizzato quasi interamente in legno massello, alcune parti interne sono in legno multistrato.

**Specchiera e illuminazione:**

Legno massello, lampade a muro in ottone dorato.

**Top:**

Marmo tecnico botticino ricomposto e lavabo sottopiano.

**Color Composition:**

Red rubbed.

**Materials:**

Made almost entirely of solid wood, several internal components of plywood.

**Mirror and Lighting:**

Solid wood, gilded brass wall lights.

**Top:**

Botticino technical recomposed marble and under-mount basin.

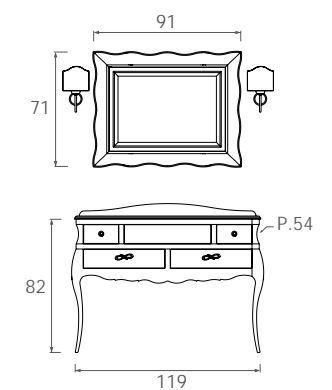



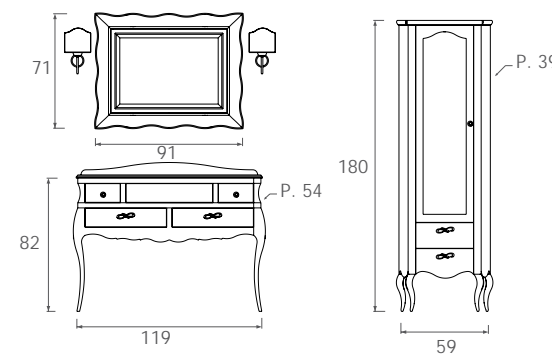

**Colore composizione:**

Bianco spigolato.

**Materiali:**

Struttura in legno massello, Ante e cassetti in legno multistrato.

**Specchiera e illuminazione:**

Specchiera in legno massello, lampade a muro in ottone cromato.

**Top:**

Marmo giallo sahara e lavabo sottopiano.

**Mobili di complemento:**

Colonna alta con anta a vetrina e due cassetti, realizzata in legno massello e multistrato.

**Color Composition:**

White rubbed.

**Materials:**

Structure in solid wood, doors and drawers of plywood.

**Mirror and Lighting:**

Mirror in solid wood, chromed brass wall lights.

**Top:**

Yellow Sahara marble and under-mount basin.

**Complementary furniture:**

Tall column with glazed door and two drawers, made of solid wood and plywood.



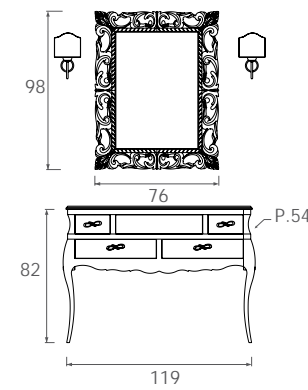

**Colore composizione:**

Rivestito interamente in foglia oro.

**Materiali:**

Realizzato quasi interamente in legno massello, alcune parti interne sono in legno multistrato.

**Specchiera e illuminazione:**

Cornice specchiera in materiale poliuretano rivestita in foglia oro e specchio bisellato, lampade a muro in ottone dorato.

**Top:**

Cristallo integrato "float spessore 15 mm", nero.

**Color Composition:**

Gold leaf finish overall.

**Materials:**

Made almost entirely of solid wood, several internal components of plywood.

**Mirror and Lighting:**

Cornice Mirror of polyurethane material finished in gold leaf and beveled mirror, wall lights of gilt brass.

**Top:**

Integrated black float glass top, 15 mm thick.





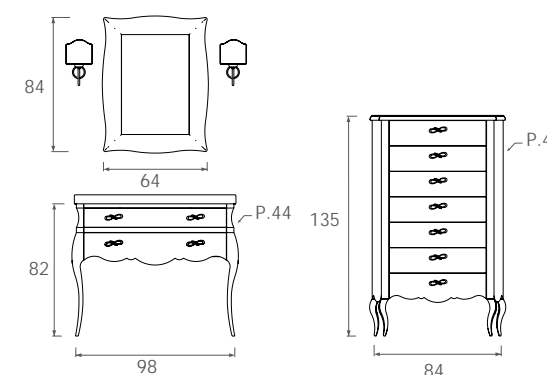

**Colore composizione:**

Laccato bianco lucido .

**Materiali:**

Realizzato quasi interamente in legno massello, alcune parti interne e frontali curvi sono in legno multistrato.

**Specchiera e illuminazione:**

Specchiera in vetro fuso con scaglie di vetro, lampade a muro in ottone cromato.

**Top:**

Lavabo integrale in ceramica.

**Mobile di complemento:**

Settimino realizzato in legno massello e multistrato.

**Color Composition:**

White gloss lacquer.

**Materials:**

Made almost entirely of solid wood, several internal components and curved fronts are made of plywood.

**Mirror and Lighting:**

Mirror in fused glass with glass, chromed brass wall lights.

**Top:**

Integral ceramic basin.

**Complementary furniture:**

Small chest of drawers made of solid wood and plywood.





**Colore composizione:**

Laccato lilla lucido.

**Materiali:**

Realizzato quasi interamente in legno massello, alcune parti interne e frontali curvi sono in legno multistrato.

**Specchiera e illuminazione:**

Legno massello, lampade a muro in ottone cromato.

**Top:**

Lavabo integrale in ceramica.

**Color Composition:**

Gloss lilac lacquer.

**Materials:**

Made almost entirely of solid wood, several internal components and curved fronts are made of plywood.

**Mirror and Lighting:**

Solid wood, chromed brass wall lights.

**Top:**

Integral ceramic basin.

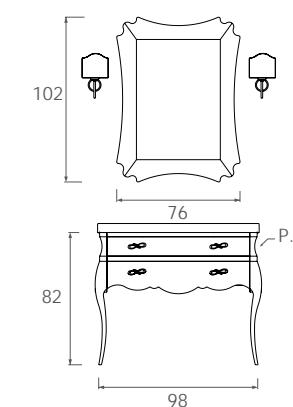

## NOVECENTO



Questo particolarissimo mobile, disponibile in unica versione con 5 cassetti, si caratterizza per le linee sinuose ed armoniche. Le finiture artigianali di pregio come l'intarsio e la particolare lavorazione delle gambe, ne fanno un oggetto unico e di grande pregio, evocando per l'appunto un arredo dei primi anni del novecento. Tecnicamente è equipaggiato di moderne guide con chiusura assistita e si può ottenere in molteplici finiture: laccato lucido e opaco, anticato, noce antico o rivestito in foglia.

*Characterized by its sinuous and harmonious lines, this unique piece of furniture is available in only this version with five drawers. The high-quality artisan finishes such as intarsia and the special carving of the legs make it a unique and extremely desirable piece that accurately evokes decor of the early twentieth century. Technically it is equipped with modern guides with assisted closure, and can be obtained in a wide range of finishes: gloss, matte, antique, antique walnut or gold/silver leaf.*

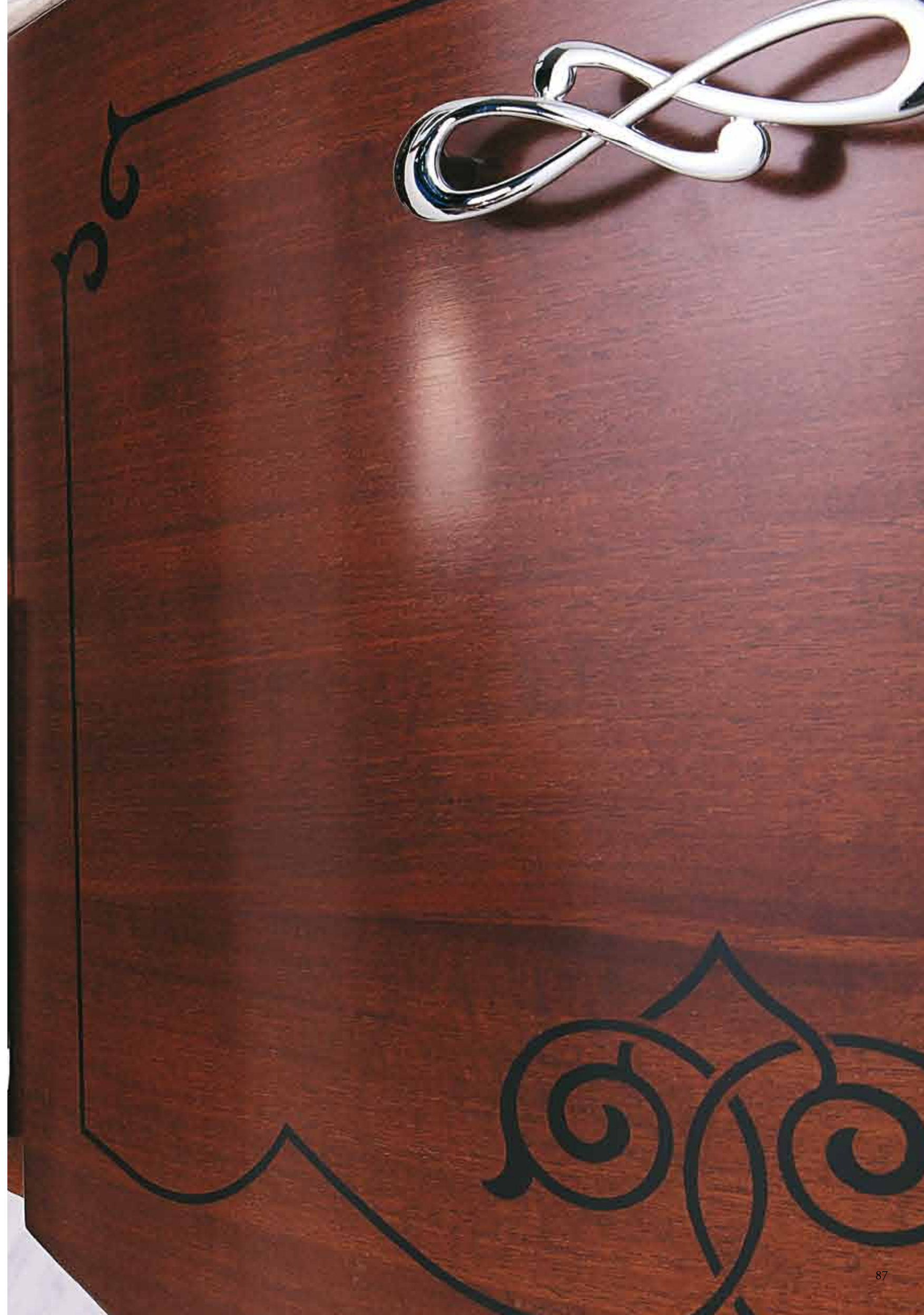



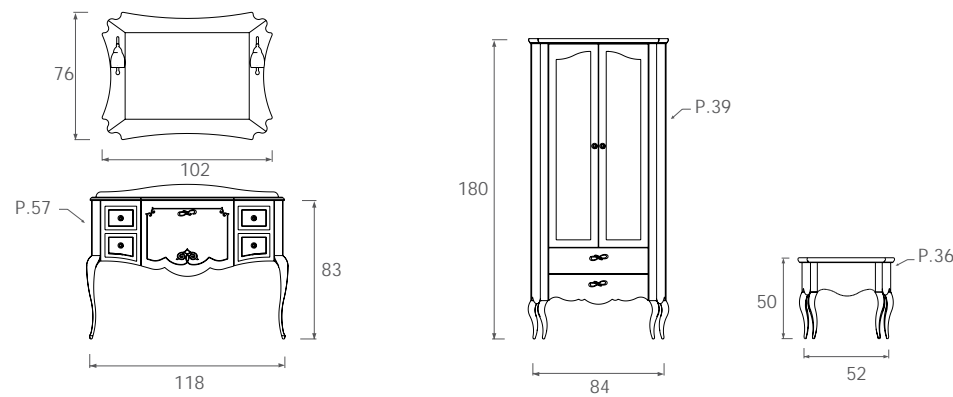

**Colore composizione:**

Noce antico.

**Materiali:**

Struttura in legno massello, cassetti in legno multistrato con intarsio ligneo.

**Specchiera e illuminazione:**

Legno massello, lampade in ottone cromato.

**Top:**

Marmo tecnico botticino ricomposto e lavabo sottopiano.

**Mobile di complemento:**

Colonna con ante a vetrina e due cassetti + sgabello contenitore, realizzati in legno massello e multistrato.

**Color Composition:**

*Antique walnut.*

**Materials:**

*Structure in solid wood, drawers of plywood with intarsia inlay.*

**Mirror and Lighting:**

*Solid wood, lamps of chromed bronze.*

**Top:**

*Botticino technical recomposed marble and under-mount basin.*

**Complementary furniture:**

*Column with glazed doors and two drawers and container stool, made of solid wood and plywood.*









**Colore composizione:**

Struttura laccato nero lucido, cassetti foglia argento.

**Materiali:**

Struttura in legno massello, cassetti in legno multistrato rivestito con foglia argento.

**Specchiera e illuminazione:**

Legno massello rivestito in foglia argento, lampade a muro in ottone cromato.

**Top:**

Cristallo integrato "float spessore 15 mm", nero.

**Color Composition:**

Structure black gloss lacquered, drawers with silver leaf finish.

**Materials:**

Structure in solid wood, drawers of plywood with silver gilt finish.

**Mirror and Lighting:**

Solid wood with silver-leaf finish, chromed brass wall lights.

**Top:**

Integrated black float glass top, 15 mm thick.

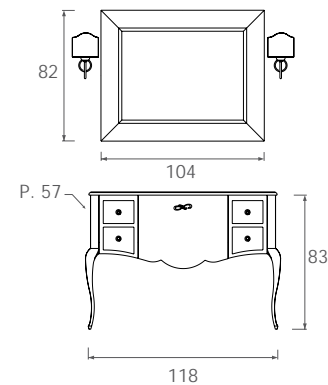





**Colore composizione:**

Sabbia antico.

**Materiali:**

Struttura in legno massello, cassetti in legno multistrato.

**Specchiera e illuminazione:**

Legno massello, lampade a muro in ottone cromato.

**Top:**

Marmo tecnico botticino ricomposto e lavabo sottopiano.

**Mobile di complemento:**

Colonna bassa con anta e due cassetti, realizzata in legno massello e multistrato.

**Color Composition:**

*Antique sand.*

**Materials:**

*Structure in solid wood, drawers of plywood.*

**Mirror and Lighting:**

*Solid wood, chromed brass wall lights.*

**Top:**

*Botticino technical recomposed marble and under-mount basin.*

**Complementary furniture:**

*Low column with door and two drawers made of solid wood and plywood.*

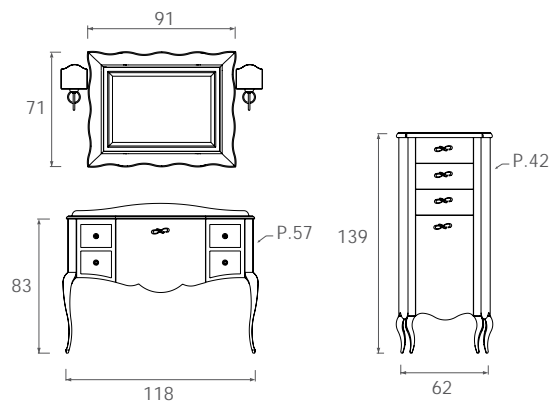





**Colore composizione:**  
Bianco lucido.

**Materiali:**  
Struttura in legno massello, cassetti in legno multistrato..

**Specchiera e illuminazione:**  
Particolare cornice a specchio curvata in fusione, lampade a muro in ottone cromato con paralume in stoffa nera.

**Top:**  
Cristallo integrato "float spessore 15 mm", nero.

**Moblie complementare:**  
Sgabello contenitore, realizzato in legno massello e multistrato.

**Color Composition:**  
White gloss.

**Materials:**  
Structure in solid wood, drawers of plywood.

**Mirror and Lighting:**  
Unusual mirror frame curved in the process of fusion, chromed brass wall lights with black fabric shades.

**Top:**  
Integrated black float glass top, 15 mm thick.

**Complementary furniture:**  
Container stool, made of solid wood and plywood.

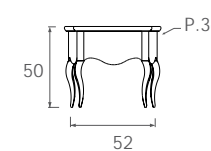
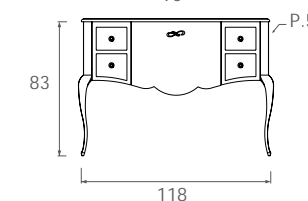
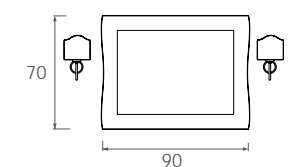

**Design**  
Studio Legnobagno

Studio21  
Fabrizio Faedda

**Grafica**  
Studio21  
Rocco Viggiano

**Camera Assistant**  
Marco Cammertoni

**Set Operator**  
Riccardo Pellegrino

**Stampa**  
Telligraf

**Ringraziamenti**  
effepi rubinetterie  
disegno ceramica

[www.legnobagno.it](http://www.legnobagno.it)

**LEGNOBAGNO®**

# LEGNOBAGNO

**LEGNOBAGNO®**

STABILIMENTO PRODUTTIVO

Via Alfredo Fieramonti (Zona Industriale) 04012 Cisterna di Latina (LT)

Tel: 06.9680943 - Fax: 06.9680948

Web: [www.legnobagno.it](http://www.legnobagno.it) E-mail: [info@legnobagno.it](mailto:info@legnobagno.it)